



## 8 Mbit (1Mb x 8) UV EPROM and OTP EPROM

- 5V  $\pm$  10% SUPPLY VOLTAGE in READ OPERATION
- ACCESS TIME: 45ns
- LOW POWER CONSUMPTION:
  - Active Current 35mA at 5MHz
  - Standby Current 100 $\mu$ A
- PROGRAMMING VOLTAGE: 12.75V  $\pm$  0.25V
- PROGRAMMING TIME: 50 $\mu$ s/word
- ELECTRONIC SIGNATURE
  - Manufacturer Code: 20h
  - Device Code: 42h

### DESCRIPTION

The M27C801 is an 8 Mbit EPROM offered in the two ranges UV (ultra violet erase) and OTP (one time programmable). It is ideally suited for applications where fast turn-around and pattern experimentation are important requirements and is organized as 1,048,576 by 8 bits.

The FDIP32W (window ceramic frit-seal package) has transparent lid which allows the user to expose the chip to ultraviolet light to erase the bit pattern. A new pattern can then be written to the device by following the programming procedure.

For applications where the content is programmed only one time and erasure is not required, the M27C801 is offered in PDIP32, PLCC32 and TSOP32 (8 x 20 mm) packages.

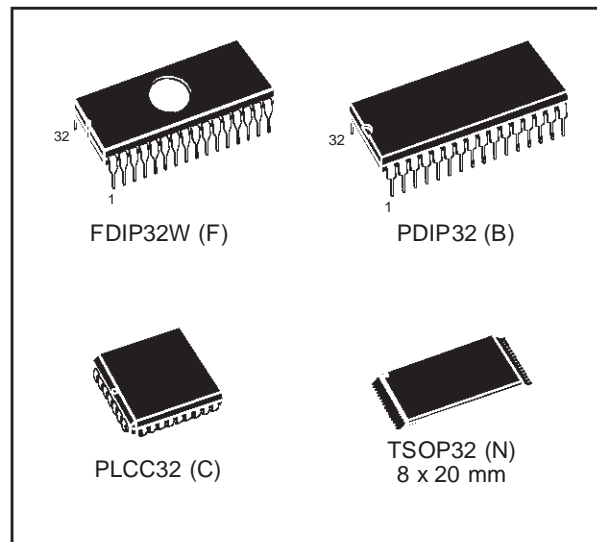
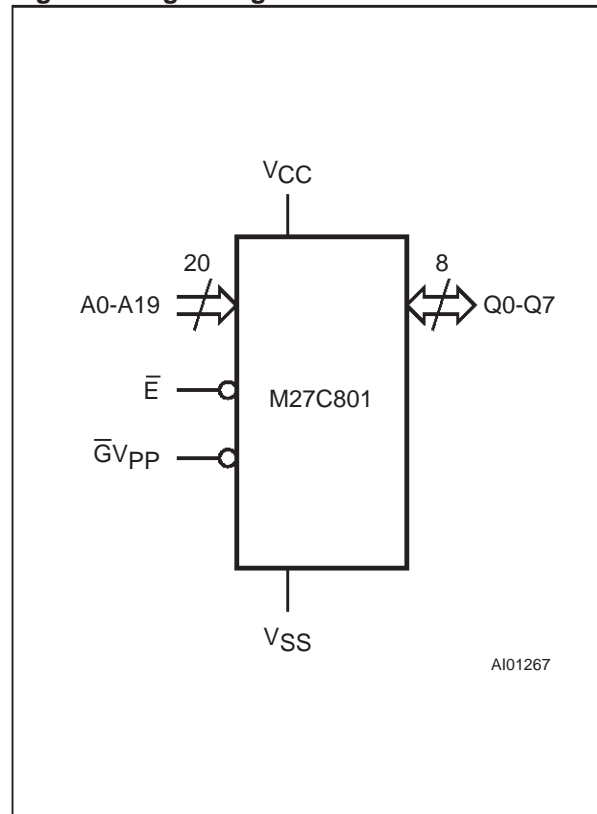
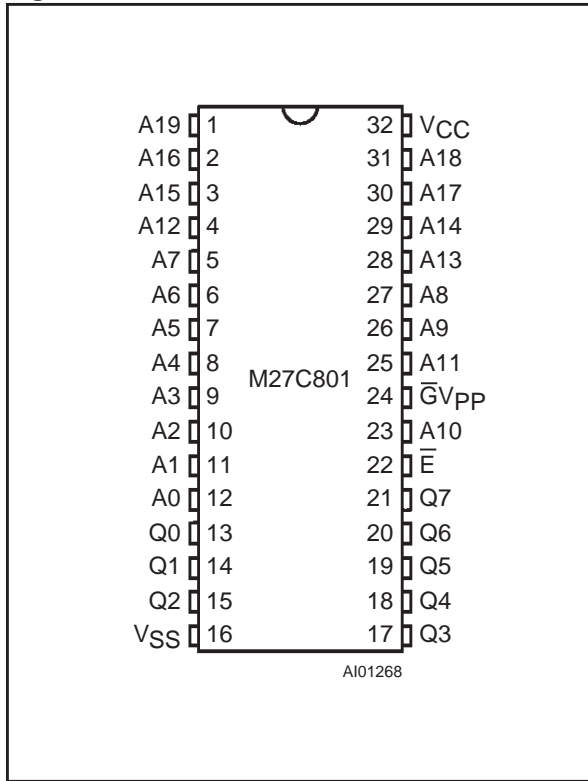

Figure 1. Logic Diagram



# M27C801

**Figure 2A. DIP Connections**



**Figure 2B. PLCC Connections**

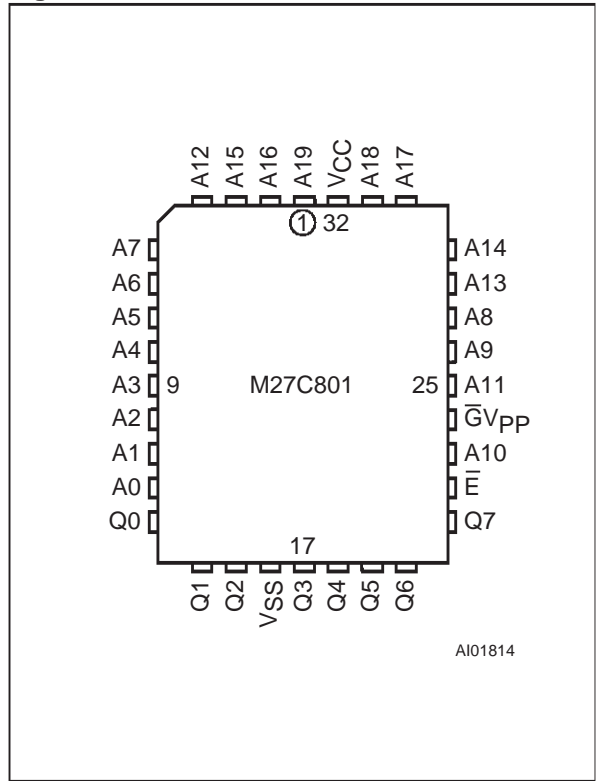

**Figure 2C. TSOP Connections**

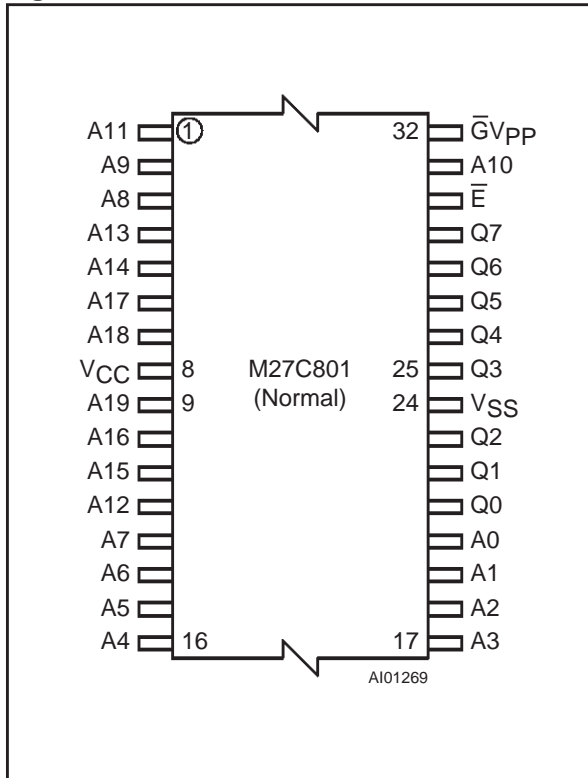

**Table 1. Signal Names**

A0-A19	Address Inputs
Q0-Q7	Data Outputs
E	Chip Enable
$\bar{G}V_{PP}$	Output Enable / Program Supply
V <sub>CC</sub>	Supply Voltage
V <sub>SS</sub>	Ground

**Table 2. Absolute Maximum Ratings (1)**

Symbol	Parameter	Value	Unit
T <sub>A</sub>	Ambient Operating Temperature (3)	-40 to 125	°C
T <sub>BIAS</sub>	Temperature Under Bias	-50 to 125	°C
T <sub>STG</sub>	Storage Temperature	-65 to 150	°C
V <sub>IO</sub> (2)	Input or Output Voltage (except A9)	-2 to 7	V
V <sub>CC</sub>	Supply Voltage	-2 to 7	V
V <sub>A9</sub> (2)	A9 Voltage	-2 to 13.5	V
V <sub>PP</sub>	Program Supply Voltage	-2 to 14	V

Note: 1. Except for the rating "Operating Temperature Range", stresses above those listed in the Table "Absolute Maximum Ratings" may cause permanent damage to the device. These are stress ratings only and operation of the device at these or any other conditions above those indicated in the Operating sections of this specification is not implied. Exposure to Absolute Maximum Rating conditions for extended periods may affect device reliability. Refer also to the STMicroelectronics SURE Program and other relevant quality documents.

2. Minimum DC voltage on Input or Output is -0.5V with possible undershoot to -2.0V for a period less than 20ns. Maximum DC voltage on Output is V<sub>CC</sub> +0.5V with possible overshoot to V<sub>CC</sub> +2V for a period less than 20ns.
3. Depends on range.

**Table 3. Operating Modes**

Mode	$\bar{E}$	$\bar{G}V_{pp}$	A9	Q7-Q0
Read	V <sub>IL</sub>	V <sub>IL</sub>	X	Data Out
Output Disable	V <sub>IL</sub>	V <sub>IH</sub>	X	Hi-Z
Program	V <sub>IL</sub> Pulse	V <sub>PP</sub>	X	Data In
Program Inhibit	V <sub>IH</sub>	V <sub>PP</sub>	X	Hi-Z
Standby	V <sub>IH</sub>	X	X	Hi-Z
Electronic Signature	V <sub>IL</sub>	V <sub>IL</sub>	V <sub>ID</sub>	Codes

Note: X = V<sub>IH</sub> or V<sub>IL</sub>, V<sub>ID</sub> = 12V ± 0.5V.

**Table 4. Electronic Signature**

Identifier	A0	Q7	Q6	Q5	Q4	Q3	Q2	Q1	Q0	Hex Data
Manufacturer's Code	V <sub>IL</sub>	0	0	1	0	0	0	0	0	20h
Device Code	V <sub>IH</sub>	0	1	0	0	0	0	1	0	42h

**Table 5. AC Measurement Conditions**

	High Speed	Standard
Input Rise and Fall Times	≤ 10ns	≤ 20ns (10% to 90%)
Input Pulse Voltages	0 to 3V	0.4 to 2.4V
Input and Output Timing Ref. Voltages	1.5V	0.8 and 2V

**Figure 3. AC Testing Input Output Waveform**

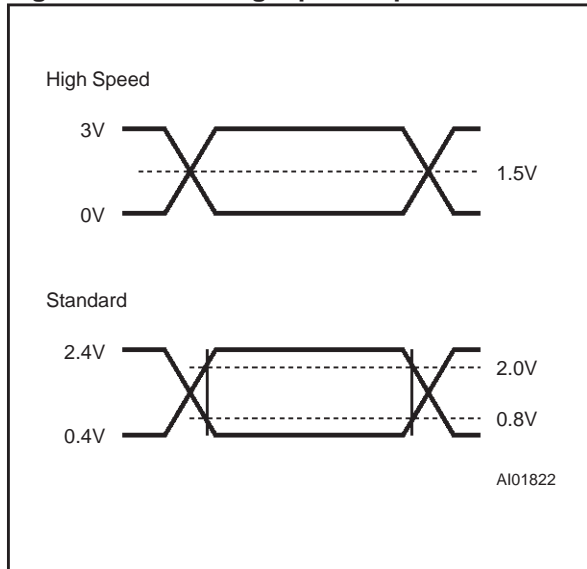

**Figure 4. AC Testing Load Circuit**

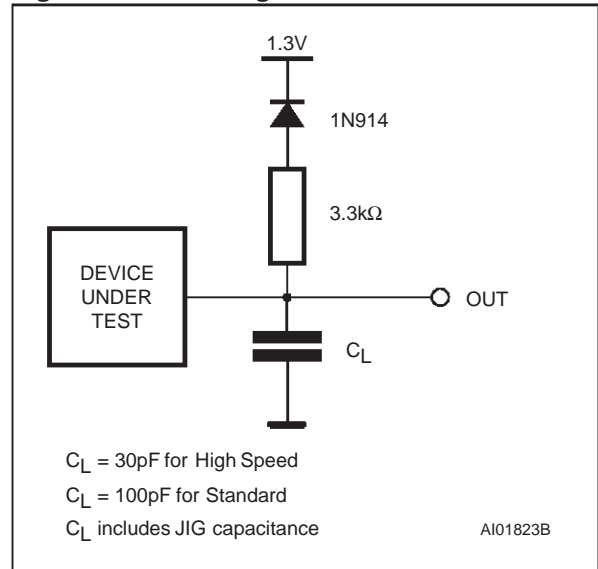

**Table 6. Capacitance <sup>(1)</sup> (T<sub>A</sub> = 25 °C, f = 1 MHz)**

Symbol	Parameter	Test Condition	Min	Max	Unit
C <sub>IN</sub>	Input Capacitance	V <sub>IN</sub> = 0V		6	pF
C <sub>OUT</sub>	Output Capacitance	V <sub>OUT</sub> = 0V		12	pF

Note: 1. Sampled only, not 100% tested.

**DEVICE OPERATION**

The operating modes of the M27C801 are listed in the Operating Modes table. A single power supply is required in the read mode. All inputs are TTL levels except for  $\overline{GV}_{PP}$  and 12V on A9 for Electronic Signature and Margin Mode Set or Reset.

**Read Mode**

The M27C801 has two control functions, both of which must be logically active in order to obtain data at the outputs. Chip Enable ( $\overline{E}$ ) is the power control and should be used for device selection. Output Enable ( $\overline{G}$ ) is the output control and should be used to gate data to the output pins, independent of device selection. Assuming that the ad-

resses are stable, the address access time (t<sub>AVQV</sub>) is equal to the delay from  $\overline{E}$  to output (t<sub>ELQV</sub>). Data is available at the output after a delay of t<sub>GLQV</sub> from the falling edge of  $\overline{G}$ , assuming that  $\overline{E}$  has been low and the addresses have been stable for at least t<sub>AVQV</sub>-t<sub>GLQV</sub>.

**Standby Mode**

The M27C801 has a standby mode which reduces the supply current from 35mA to 100μA.

The M27C801 is placed in the standby mode by applying a CMOS high signal to the  $\overline{E}$  input. When in the standby mode, the outputs are in a high impedance state, independent of the  $\overline{GV}_{PP}$  input.

**Table 7. Read Mode DC Characteristics (1)**(T<sub>A</sub> = 0 to 70 °C or -40 to 85 °C; V<sub>CC</sub> = 5V ± 10%)

Symbol	Parameter	Test Condition	Min	Max	Unit
I <sub>LI</sub>	Input Leakage Current	0V ≤ V <sub>IN</sub> ≤ V <sub>CC</sub>		±10	μA
I <sub>LO</sub>	Output Leakage Current	0V ≤ V <sub>OUT</sub> ≤ V <sub>CC</sub>		±10	μA
I <sub>CC</sub>	Supply Current	$\bar{E} = V_{IL}, \bar{G}V_{PP} = V_{IL}, I_{OUT} = 0\text{mA}, f = 5\text{MHz}$		35	mA
I <sub>CC1</sub>	Supply Current (Standby) TTL	$\bar{E} = V_{IH}$		1	mA
I <sub>CC2</sub>	Supply Current (Standby) CMOS	$\bar{E} > V_{CC} - 0.2\text{V}$		100	μA
I <sub>PP</sub>	Program Current	V <sub>PP</sub> = V <sub>CC</sub>		10	μA
V <sub>IL</sub>	Input Low Voltage		-0.3	0.8	V
V <sub>IH</sub> (2)	Input High Voltage		2	V <sub>CC</sub> + 1	V
V <sub>OL</sub>	Output Low Voltage	I <sub>OL</sub> = 2.1mA		0.4	V
V <sub>OH</sub>	Output High Voltage TTL	I <sub>OH</sub> = -1mA	3.6		V
	Output High Voltage CMOS	I <sub>OH</sub> = -100μA	V <sub>CC</sub> - 0.7		V

Note: 1. V<sub>CC</sub> must be applied simultaneously with or before V<sub>PP</sub> and removed simultaneously or after V<sub>PP</sub>.2. Maximum DC voltage on Output is V<sub>CC</sub> + 0.5V.**Table 8A. Read Mode AC Characteristics (1)**(T<sub>A</sub> = 0 to 70 °C or -40 to 85 °C; V<sub>CC</sub> = 5V ± 10%)

Symbol	Alt	Parameter	Test Condition	M27C801						Unit
				-45 (3)		-60		-70		
				Min	Max	Min	Max	Min	Max	
t <sub>AVQV</sub>	t <sub>ACC</sub>	Address Valid to Output Valid	$\bar{E} = V_{IL}, \bar{G}V_{PP} = V_{IL}$		45		60		70	ns
t <sub>ELQV</sub>	t <sub>CE</sub>	Chip Enable Low to Output Valid	$\bar{G}V_{PP} = V_{IL}$		45		60		70	ns
t <sub>GLQV</sub>	t <sub>OE</sub>	Output Enable Low to Output Valid	$\bar{E} = V_{IL}$		25		30		35	ns
t <sub>EHQZ</sub> (2)	t <sub>DF</sub>	Chip Enable High to Output Hi-Z	$\bar{G}V_{PP} = V_{IL}$	0	25	0	25	0	30	ns
t <sub>GHQZ</sub> (2)	t <sub>DF</sub>	Output Enable High to Output Hi-Z	$\bar{E} = V_{IL}$	0	25	0	25	0	30	ns
t <sub>AXQX</sub>	t <sub>OH</sub>	Address Transition to Output Transition	$\bar{E} = V_{IL}, \bar{G}V_{PP} = V_{IL}$	0		0		0		ns

Note: 1. V<sub>CC</sub> must be applied simultaneously with or before V<sub>PP</sub> and removed simultaneously or after V<sub>PP</sub>.

2. Sampled only, not 100% tested.

3. Speed obtained with High Speed AC measurement conditions.

## Two Line Output Control

Because EPROMs are usually used in larger memory arrays, the product features a 2 line control function which accommodates the use of multiple memory connection. The two line control function allows:

- the lowest possible memory power dissipation,
- complete assurance that output bus contention will not occur.

For the most efficient use of these two control lines,  $\bar{E}$  should be decoded and used as the primary device selecting function, while  $\bar{G}$  should be made a common connection to all devices in the array and connected to the  $\overline{\text{READ}}$  line from the system control bus. This ensures that all deselected memory devices are in their low power standby mode and that the output pins are only active when data is required from a particular memory device.

**Table 8B. Read Mode AC Characteristics (1)**  
 (T<sub>A</sub> = 0 to 70 °C or -40 to 85 °C; V<sub>CC</sub> = 5V ± 10%)

Symbol	Alt	Parameter	Test Condition	M27C801				Unit
				-80		-100/-120/-150		
				Min	Max	Min	Max	
t <sub>AVQV</sub>	t <sub>ACC</sub>	Address Valid to Output Valid	$\bar{E} = V_{IL}, \bar{G}V_{PP} = V_{IL}$		80		100	ns
t <sub>ELQV</sub>	t <sub>CE</sub>	Chip Enable Low to Output Valid	$\bar{G}V_{PP} = V_{IL}$		80		100	ns
t <sub>GLQV</sub>	t <sub>OE</sub>	Output Enable Low to Output Valid	$\bar{E} = V_{IL}$		40		50	ns
t <sub>EHQZ</sub> (2)	t <sub>DF</sub>	Chip Enable High to Output Hi-Z	$\bar{G}V_{PP} = V_{IL}$	0	35	0	40	ns
t <sub>GHQZ</sub> (2)	t <sub>DF</sub>	Output Enable High to Output Hi-Z	$\bar{E} = V_{IL}$	0	35	0	40	ns
t <sub>AXQX</sub>	t <sub>OH</sub>	Address Transition to Output Transition	$\bar{E} = V_{IL}, \bar{G}V_{PP} = V_{IL}$	0		0		ns

Note: 1. V<sub>CC</sub> must be applied simultaneously with or before V<sub>PP</sub> and removed simultaneously or after V<sub>PP</sub>.  
 2. Sampled only, not 100% tested.

**Figure 5. Read Mode AC Waveforms**

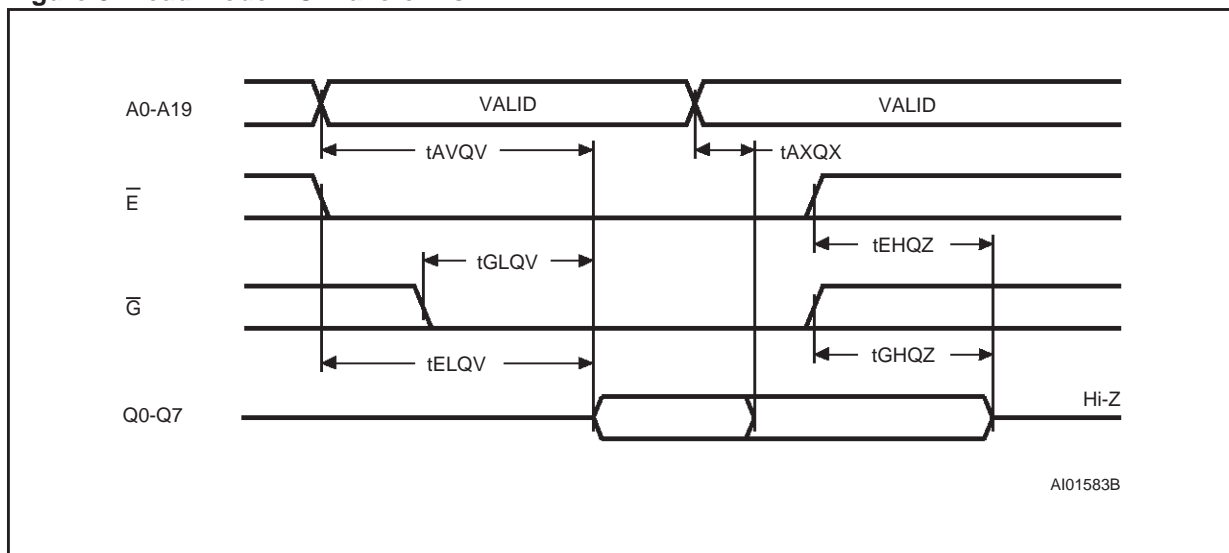

**System Considerations**

The power switching characteristics of Advanced CMOS EPROMs require careful decoupling of the devices. The supply current, I<sub>CC</sub>, has three segments that are of interest to the system designer: the standby current level, the active current level, and transient current peaks that are produced by the falling and rising edges of  $\bar{E}$ . The magnitude of the transient current peaks is dependent on the capacitive and inductive loading of the device at the output. The associated transient voltage peaks can be suppressed by complying with the two line

output control and by properly selected decoupling capacitors. It is recommended that a 0.1µF ceramic capacitor be used on every device between V<sub>CC</sub> and V<sub>SS</sub>. This should be a high frequency capacitor of low inherent inductance and should be placed as close to the device as possible. In addition, a 4.7µF bulk electrolytic capacitor should be used between V<sub>CC</sub> and V<sub>SS</sub> for every eight devices. The bulk capacitor should be located near the power supply connection point. The purpose of the bulk capacitor is to overcome the voltage drop caused by the inductive effects of PCB traces.

**Table 9. Programming Mode DC Characteristics (1)**  
 ( $T_A = 25\text{ }^\circ\text{C}$ ;  $V_{CC} = 6.25\text{V} \pm 0.25\text{V}$ ;  $V_{PP} = 12.75\text{V} \pm 0.25\text{V}$ )

Symbol	Parameter	Test Condition	Min	Max	Unit
$I_{LI}$	Input Leakage Current	$V_{IL} \leq V_{IN} \leq V_{IH}$		$\pm 10$	$\mu\text{A}$
$I_{CC}$	Supply Current			50	mA
$I_{PP}$	Program Current	$\bar{E} = V_{IL}$		50	mA
$V_{IL}$	Input Low Voltage		-0.3	0.8	V
$V_{IH}$	Input High Voltage		2	$V_{CC} + 0.5$	V
$V_{OL}$	Output Low Voltage	$I_{OL} = 2.1\text{mA}$		0.4	V
$V_{OH}$	Output High Voltage TTL	$I_{OH} = -1\text{mA}$	3.6		V
$V_{ID}$	A9 Voltage		11.5	12.5	V

Note: 1.  $V_{CC}$  must be applied simultaneously with or before  $V_{PP}$  and removed simultaneously or after  $V_{PP}$ .

**Table 10. MARGIN MODE AC Characteristics (1)**  
 ( $T_A = 25\text{ }^\circ\text{C}$ ;  $V_{CC} = 6.25\text{V} \pm 0.25\text{V}$ ;  $V_{PP} = 12.75\text{V} \pm 0.25\text{V}$ )

Symbol	Alt	Parameter	Test Condition	Min	Max	Unit
$t_{A9HVPH}$	$t_{AS9}$	$V_{A9}$ High to $V_{PP}$ High		2		$\mu\text{s}$
$t_{VPHEL}$	$t_{VPS}$	$V_{PP}$ High to Chip Enable Low		2		$\mu\text{s}$
$t_{A10HEH}$	$t_{AS10}$	$V_{A10}$ High to Chip Enable High (Set)		1		$\mu\text{s}$
$t_{A10LEH}$	$t_{AS10}$	$V_{A10}$ Low to Chip Enable High (Reset)		1		$\mu\text{s}$
$t_{EXA10X}$	$t_{AH10}$	Chip Enable Transition to $V_{A10}$ Transition		1		$\mu\text{s}$
$t_{EXVPX}$	$t_{VPH}$	Chip Enable Transition to $V_{PP}$ Transition		2		$\mu\text{s}$
$t_{VPXA9X}$	$t_{AH9}$	$V_{PP}$ Transition to $V_{A9}$ Transition		2		$\mu\text{s}$

Note: 1.  $V_{CC}$  must be applied simultaneously with or before  $V_{PP}$  and removed simultaneously or after  $V_{PP}$ .

## Programming

When delivered (and after each erasure for UV EPROM), all bits of the M27C801 are in the '1' state. Data is introduced by selectively programming '0's into the desired bit locations. Although only '0' will be programmed, both '1's and '0's can be present in the data word. The only way to change a '0' to a '1' is by die exposure to ultraviolet

light (UV EPROM). The M27C801 is in the programming mode when  $V_{PP}$  input is at 12.75V and  $\bar{E}$  is pulsed to  $V_{IL}$ . The data to be programmed is applied to 8 bits in parallel to the data output pins. The levels required for the address and data inputs are TTL.  $V_{CC}$  is specified to be  $6.25\text{V} \pm 0.25\text{V}$ .

Figure 6. MARGIN MODE AC Waveforms

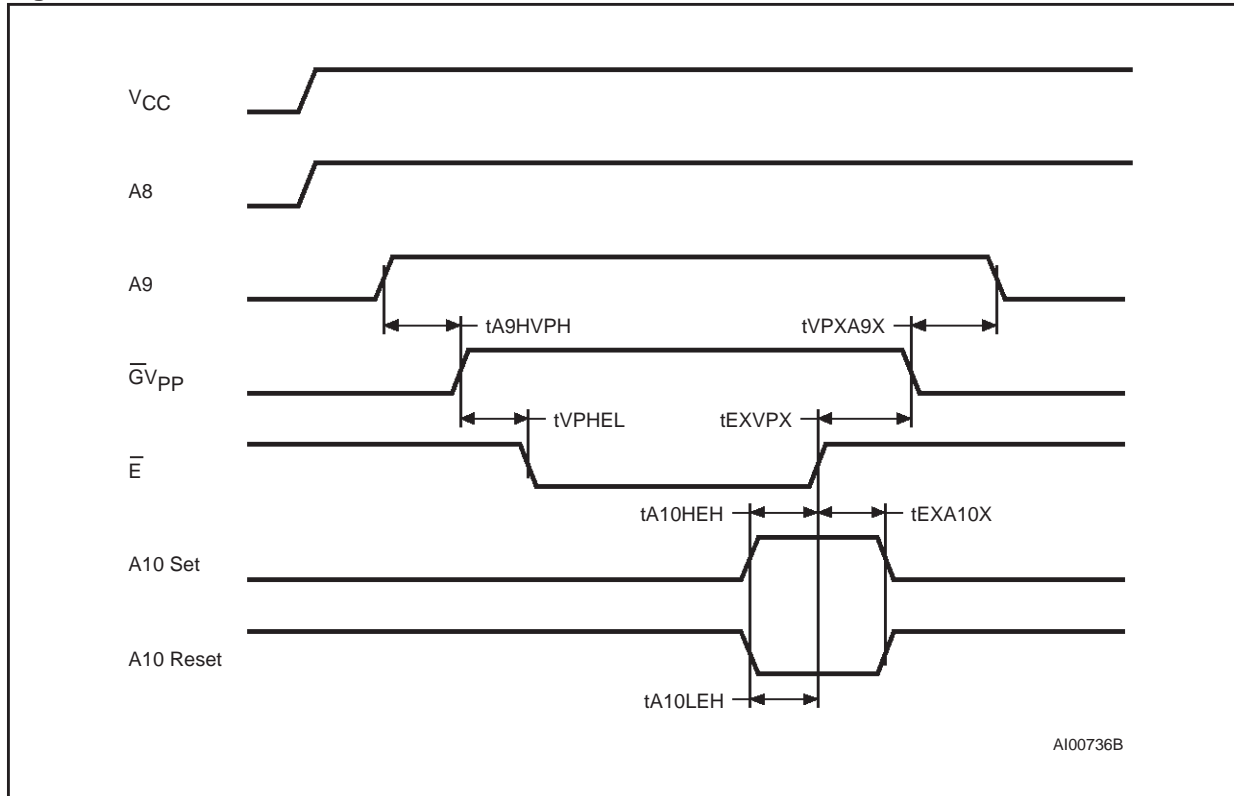

Note: A8 High level = 5V; A9 High level = 12V.

Table 11. Programming Mode DC Characteristics (1)  
(T<sub>A</sub> = 25 °C; V<sub>CC</sub> = 6.25V ± 0.25V; V<sub>PP</sub> = 12.75V ± 0.25V)

Symbol	Alt	Parameter	Test Condition	Min	Max	Unit
t <sub>AVEL</sub>	t <sub>AS</sub>	Address Valid to Chip Enable Low		2		μs
t <sub>QVEL</sub>	t <sub>DS</sub>	Input Valid to Chip Enable Low		2		μs
t <sub>VCHL</sub>	t <sub>VCS</sub>	V <sub>CC</sub> High to Chip Enable Low		2		μs
t <sub>VPHEL</sub>	t <sub>OES</sub>	V <sub>PP</sub> High to Chip Enable Low		2		μs
t <sub>VPLVPH</sub>	t <sub>PRT</sub>	V <sub>PP</sub> Rise Time		50		ns
t <sub>ELEH</sub>	t <sub>PW</sub>	Chip Enable Program Pulse Width (Initial)		45	55	μs
t <sub>EHQX</sub>	t <sub>DH</sub>	Chip Enable High to Input Transition		2		μs
t <sub>EHVPX</sub>	t <sub>OEH</sub>	Chip Enable High to V <sub>PP</sub> Transition		2		μs
t <sub>VPLEL</sub>	t <sub>VR</sub>	V <sub>PP</sub> Low to Chip Enable Low		2		μs
t <sub>ELQV</sub>	t <sub>DV</sub>	Chip Enable Low to Output Valid			1	μs
t <sub>EHQZ</sub> (2)	t <sub>DFP</sub>	Chip Enable High to Output Hi-Z		0	130	ns
t <sub>EHAX</sub>	t <sub>AH</sub>	Chip Enable High to Address Transition		0		ns

Note: 1. V<sub>CC</sub> must be applied simultaneously with or before V<sub>PP</sub> and removed simultaneously or after V<sub>PP</sub>.  
2. Sampled only, not 100% tested.

Figure 7. Programming and Verify Modes AC Waveforms

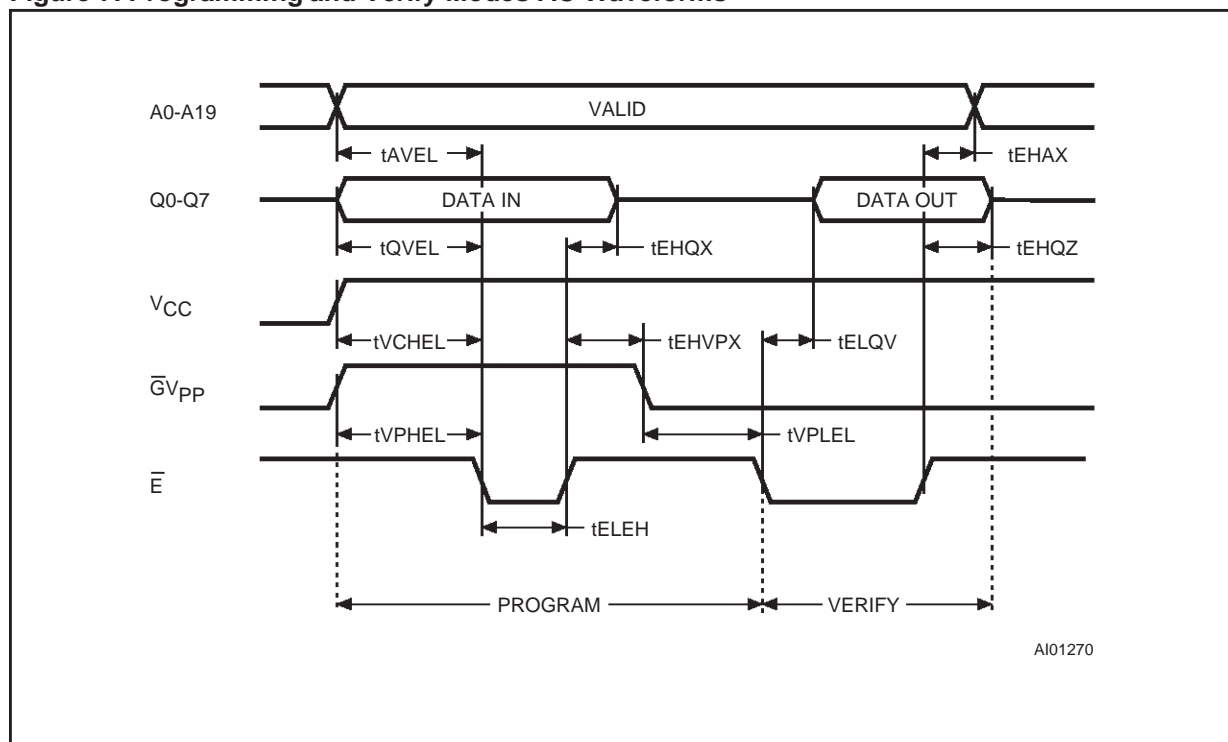
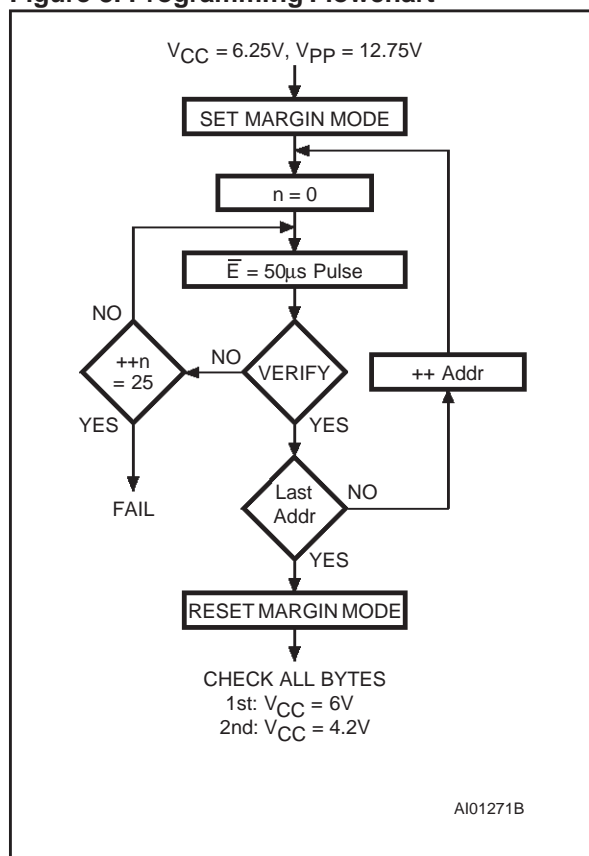

Figure 8. Programming Flowchart



### PRESTO IIB Programming Algorithm

PRESTO IIB Programming Algorithm allows the whole array to be programmed with a guaranteed margin, in a typical time of 52.5 seconds. This can be achieved with STMicroelectronics M27C801 due to several design innovations to improve programming efficiency and to provide adequate margin for reliability. Before starting the programming the internal MARGIN MODE circuit is set in order to guarantee that each cell is programmed with enough margin. Then a sequence of 50µs program pulses are applied to each byte until a correct verify occurs. No overprogram pulses are applied since the verify in MARGIN MODE provides the necessary margin.

### Program Inhibit

Programming of multiple M27C801s in parallel with different data is also easily accomplished. Except for  $\bar{E}$ , all like inputs including  $\bar{G}V_{PP}$  of the parallel M27C801 may be common. A TTL low level pulse applied to a M27C801's  $\bar{E}$  input, with  $V_{PP}$  at 12.75V, will program that M27C801. A high level  $\bar{E}$  input inhibits the other M27C801s from being programmed.

### Program Verify

A verify (read) should be performed on the programmed bits to determine that they were correctly programmed. The verify is accomplished with  $\bar{G}$  at  $V_{IL}$ . Data should be verified with t<sub>ELQV</sub> after the falling edge of  $\bar{E}$ .

### On-Board Programming

The M27C801 can be directly programmed in the application circuit. See the relevant Application Note AN620.

### Electronic Signature

The Electronic Signature (ES) mode allows the reading out of a binary code from an EPROM that will identify its manufacturer and type. This mode is intended for use by programming equipment to automatically match the device to be programmed with its corresponding programming algorithm. The ES mode is functional in the  $25^{\circ}\text{C} \pm 5^{\circ}\text{C}$  ambient temperature range that is required when programming the M27C801. To activate the ES mode, the programming equipment must force 11.5V to 12.5V on address line A9 of the M27C801. Two identifier bytes may then be sequenced from the device outputs by toggling address line A0 from  $V_{IL}$  to  $V_{IH}$ . All other address lines must be held at  $V_{IL}$  during Electronic Signature mode. Byte 0 ( $A0 = V_{IL}$ ) represents the manufacturer code and byte 1 ( $A0 = V_{IH}$ ) the device identifier code. For the STMicroelectronics M27C801, these two identifier bytes are given in Table 4 and can be read-out on outputs Q7 to Q0.

### ERASURE OPERATION (applies to UV EPROM)

The erasure characteristics of the M27C801 is such that erasure begins when the cells are exposed to light with wavelengths shorter than approximately 4000 Å. It should be noted that sunlight and some type of fluorescent lamps have wavelengths in the 3000-4000 Å range.

Research shows that constant exposure to room level fluorescent lighting could erase a typical M27C801 in about 3 years, while it would take approximately 1 week to cause erasure when exposed to direct sunlight. If the M27C801 is to be exposed to these types of lighting conditions for extended periods of time, it is suggested that opaque labels be put over the M27C801 window to prevent unintentional erasure. The recommended erasure procedure for the M27C801 is exposure to short wave ultraviolet light which has wavelength 2537 Å. The integrated dose (i.e. UV intensity x exposure time) for erasure should be a minimum of 30 W-sec/cm<sup>2</sup>. The erasure time with this dosage is approximately 30 to 40 minutes using an ultraviolet lamp with 12000 μW/cm<sup>2</sup> power rating. The M27C801 should be placed within 2.5 cm (1 inch) of the lamp tubes during the erasure. Some lamps have a filter on their tubes which should be removed before erasure.

**Table 12. Ordering Information Scheme**

Example:	M27C801	-45	K	1	TR
<b>Device Type</b> M27					
<b>Supply Voltage</b> C = 5V ±10%					
<b>Device Function</b> 801 = 8Mbit (1Mb x8)					
<b>Speed</b> -45 <sup>(1)</sup> = 45 ns -60 = 60 ns -70 = 70 ns -80 = 80 ns -100 = 100 ns -120 = 120 ns -150 = 150 ns					
<b>Package</b> F = FDIP32W B = PDIP32 K = PLCC32 N = TSOP32: 8 x 20 mm					
<b>Temperature Range</b> 1 = 0 to 70 °C 6 = -40 to 85 °C					
<b>Options</b> X = Additional Burn-in TR = Tape & Reel Packing					

Note: 1. High Speed, see AC Characteristics section for further information.

For a list of available options (Speed, Package, etc...) or for further information on any aspect of this device, please contact the STMicroelectronics Sales Office nearest to you.

**Table 1. Revision History**

Date	Revision Details
September 1998	First Issue
03/21/00	FDIP32W Package changed

Table 13. FDIP32W - 32 pin Ceramic Frit-seal DIP with window, Package Mechanical Data

Symb	mm			inches			
	Typ	Min	Max	Typ	Min	Max	
A			5.72			0.225	
A1		0.51	1.40		0.020	0.055	
A2		3.91	4.57		0.154	0.180	
A3		3.89	4.50		0.153	0.177	
B		0.41	0.56		0.016	0.022	
B1	1.45	–	–	0.057	–	–	
C		0.23	0.30		0.009	0.012	
D		41.73	42.04		1.643	1.655	
D2	38.10	–	–	1.500	–	–	
E	15.24	–	–	0.600	–	–	
E1		13.06	13.36		0.514	0.526	
e	2.54	–	–	0.100	–	–	
eA	14.99	–	–	0.590	–	–	
eB		16.18	18.03		0.637	0.710	
L		3.18			0.125		
S		1.52	2.49		0.060	0.098	
∅	7.11	–	–	0.280	–	–	
α		4°	11°		4°	11°	
N		32				32	

Figure 9. FDIP32W - 32 pin Ceramic Frit-seal DIP with window, Package Outline

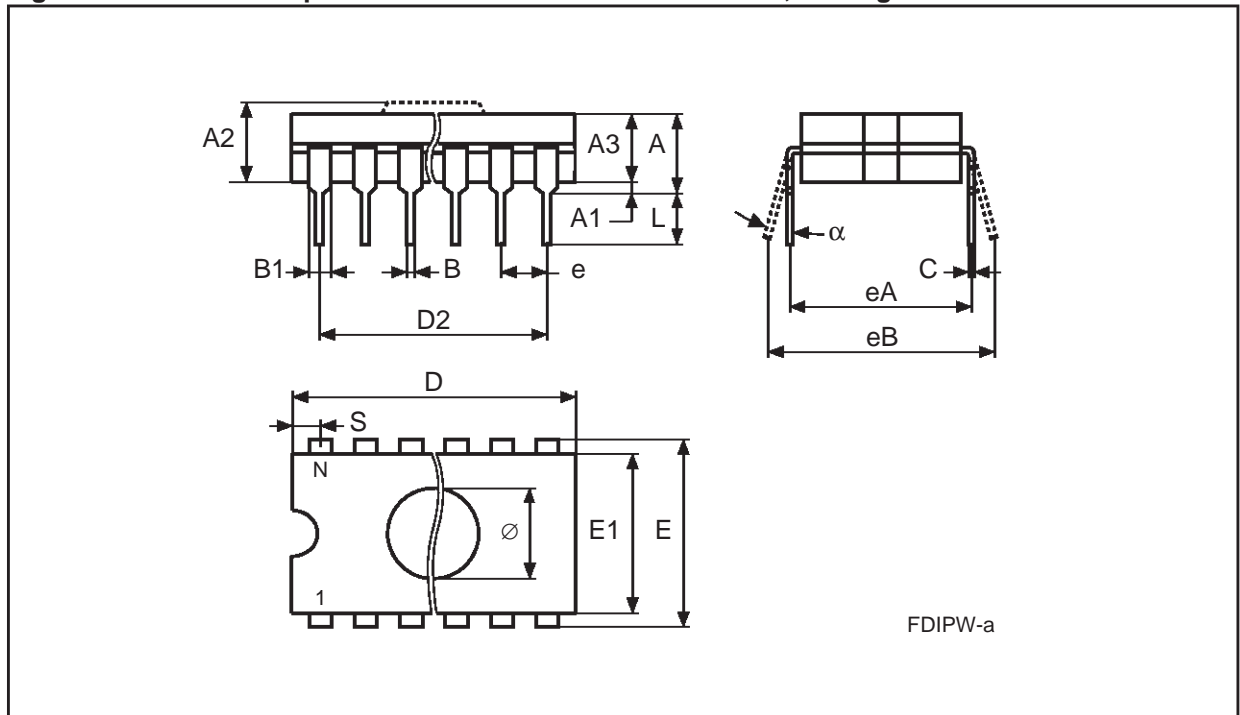

Drawing is not to scale.

Table 14. PDIP32 - 32 pin Plastic DIP, 600 mils width, Package Mechanical Data

Symb	mm			inches		
	Typ	Min	Max	Typ	Min	Max
A		–	5.08		–	0.200
A1		0.38	–		0.015	–
A2		3.56	4.06		0.140	0.160
B		0.38	0.51		0.015	0.020
B1	1.52	–	–	0.060	–	–
C		0.20	0.30		0.008	0.012
D		41.78	42.04		1.645	1.655
D2	38.10	–	–	1.500	–	–
E	15.24	–	–	0.600	–	–
E1		13.59	13.84		0.535	0.545
e1	2.54	–	–	0.100	–	–
eA	15.24	–	–	0.600	–	–
eB		15.24	17.78		0.600	0.700
L		3.18	3.43		0.125	0.135
S		1.78	2.03		0.070	0.080
$\alpha$		0°	10°		0°	10°
N		32			32	

Figure 10. PDIP32 - 32 pin Plastic DIP, 600 mils width, Package Outline

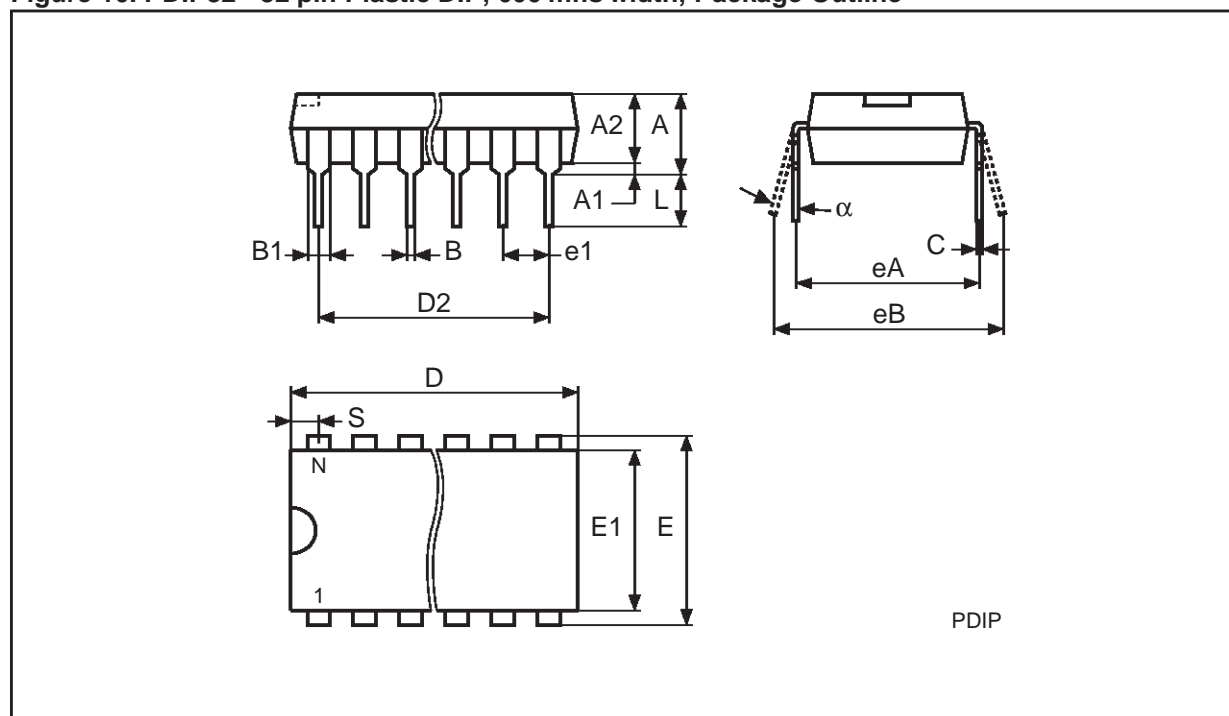

Drawing is not to scale.

Table 15. PLCC32 - 32 lead Plastic Leaded Chip Carrier, Package Mechanical Data

Symb	mm			inches		
	Typ	Min	Max	Typ	Min	Max
A		2.54	3.56		0.100	0.140
A1		1.52	2.41		0.060	0.095
A2		–	0.38		–	0.015
B		0.33	0.53		0.013	0.021
B1		0.66	0.81		0.026	0.032
D		12.32	12.57		0.485	0.495
D1		11.35	11.56		0.447	0.455
D2		9.91	10.92		0.390	0.430
E		14.86	15.11		0.585	0.595
E1		13.89	14.10		0.547	0.555
E2		12.45	13.46		0.490	0.530
e	1.27	–	–	0.050	–	–
F		0.00	0.25		0.000	0.010
R	0.89	–	–	0.035	–	–
N		32			32	
Nd		7			7	
Ne		9			9	
CP			0.10			0.004

Figure 11. PLCC32 - 32 lead Plastic Leaded Chip Carrier, Package Outline

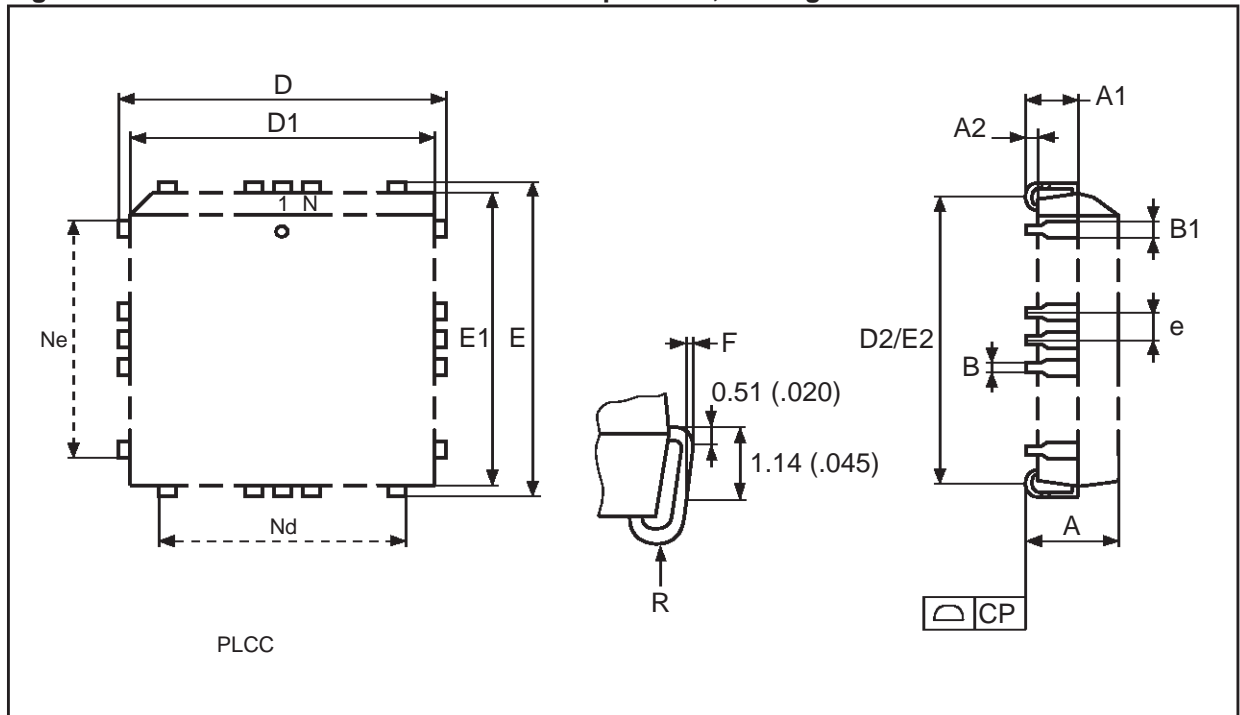

Drawing is not to scale.

Table 16. TSOP32 - 32 lead Plastic Thin Small Outline, 8 x 20 mm, Package Mechanical Data

Symb	mm			inches		
	Typ	Min	Max	Typ	Min	Max
A			1.20			0.047
A1		0.05	0.17		0.002	0.006
A2		0.95	1.05		0.037	0.041
B		0.15	0.27		0.006	0.011
C		0.10	0.21		0.004	0.008
D		19.80	20.20		0.780	0.795
D1		18.30	18.50		0.720	0.728
E		7.90	8.10		0.311	0.319
e	0.50	–	–	0.020	–	–
L		0.50	0.70		0.020	0.028
$\alpha$		0°	5°		0°	5°
N	32			32		
CP			0.10			0.004

Figure 12. TSOP32 - 32 lead Plastic Thin Small Outline, 8 x 20 mm, Package Outline

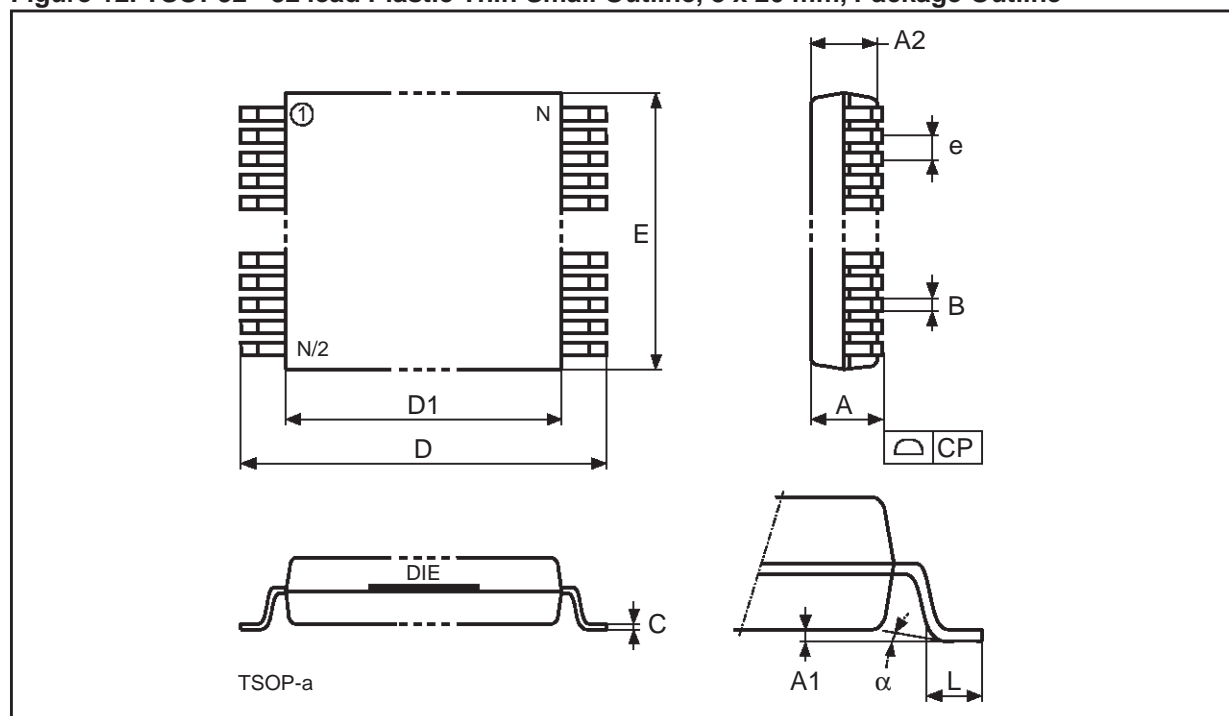

Drawing is not to scale.

Information furnished is believed to be accurate and reliable. However, STMicroelectronics assumes no responsibility for the consequences of use of such information nor for any infringement of patents or other rights of third parties which may result from its use. No license is granted by implication or otherwise under any patent or patent rights of STMicroelectronics. Specifications mentioned in this publication are subject to change without notice. This publication supersedes and replaces all information previously supplied. STMicroelectronics products are not authorized for use as critical components in life support devices or systems without express written approval of STMicroelectronics.

The ST logo is registered trademark of STMicroelectronics  
© 2000 STMicroelectronics - All Rights Reserved

All other names are the property of their respective owners.

STMicroelectronics GROUP OF COMPANIES  
Australia - Brazil - China - Finland - France - Germany - Hong Kong - India - Italy - Japan - Malaysia - Malta - Morocco -  
Singapore - Spain - Sweden - Switzerland - United Kingdom - U.S.A.

<http://www.st.com>

This datasheet has been downloaded from:

[www.DatasheetCatalog.com](http://www.DatasheetCatalog.com)

Datasheets for electronic components.