

Boca Semiconductor Corp.  
BSC  
<http://www.bocasemi.com>

Switching And Linear Application DC And VHF Amplifier Applications

ABSOLUTE MAXIMUM RATINGS

DESCRIPTION	SYMBOL	2N2221A,22A	UNIT
Collector -Emitter Voltage		40	V
Collector -Base Voltage		75	V
Emitter -Base Voltage		6.0	V
Collector Current Continuous		800	mA
Power Dissipation @ Ta=25 degC		500	mW
Derate Above 25deg C		2.28	mW/deg C
@ Tc=25 degC		1.2	W
Derate Above 25deg C		6.85	mW/deg C
Operating And Storage Junction Temperature Range	Tj, Tstg	-65 to +200	deg C

ELECTRICAL CHARACTERISTICS (Ta=25 deg C Unless Otherwise Specified)

DESCRIPTION	SYMBOL	TEST CONDITION	VALUE		UNIT
			MIN	MAX	
Collector -Emitter Voltage	VCEO	IC=10mA, IB=0	40	-	V
Collector -Base Voltage	VCBO	IC=10uA, IE=0	75	-	V
Emitter-Base Voltage	VEBO	IE=10uA, IC=0	6.0	-	V
Collector-Cut off Current	ICBO	VCB=60V, IE=0	-	10	nA
		Ta=150 deg C			
		VCB=60V, IE=0	-	10	uA
Emitter-Cut off Current	ICEX	VCE=60V, VEB=3V	-	10	nA
Base-Cut off Current	IEBO	VEB=3V, IC=0	-	10	nA
Collector Emitter Saturation Voltage	IBL	VCE=60V, VEB=3V	-	20	nA
	VCE(Sat)*	IC=150mA, IB=15mA	-	0.3	V
		IC=500mA, IB=50mA		1.0	V
Base Emitter Saturation Voltage	VBE(Sat) *	IC=150mA, IB=15mA	-	0.6-1.2	V
		IC=500mA, IB=50mA	-	2.0	V

**ELECTRICAL CHARACTERISTICS (Ta=25 deg C Unless Otherwise Specified) 2N2221A to 2N2222A**

DESCRIPTION	SYMBOL	TEST CONDITION	2221A	2222A	UNIT
DC Current Gain	hFE	IC=0.1mA, VCE=10V	>20	>35	
		IC=1mA, VCE=10V	>25	>50	
		IC=10mA, VCE=10V	>35	>75	
		Ta=55 deg C			
		IC=10mA, VCE=10V	>15	>35	
		IC=150mA, VCE=10V	40-120	100-300	
		IC=150mA, VCE=1V	>20	>50	
		IC=500mA, VCE=10V	>25	>40	
<b><u>DYNAMIC CHARACTERISTICS</u></b>					
		ALL f=1kHz			
Small Signal Current Gain	hfe	IC=1mA, VCE=10V	30-150	50-300	
		IC=10mA, VCE=10V	50-300	75-375	
Input Impedance	hie	IC=1mA, VCE=10V	1.0-3.5	2.0-8.0	kohms
		IC=10mA, VCE=10V	0.2-1.0	0.25-1.25	
Voltage Feedback Ratio	hre	IC=1mA, VCE=10V	<5.0	<8.0	x10-4
		IC=10mA, VCE=10V	<2.5	<4.0	
Out put Admittance	hoe	IC=1mA, VCE=10V	3.0-15	5.0-35	umhos
		IC=10mA, VCE=10V	10-100	25-200	
Collector Base Time Constant	rb'Cc	IE=20mA, VCB=20V	<150	<150	ps
		f=31.8MHz			
Real Part Common-Emitter High Frequency Input Impedance	Re(hie)	IC=20mA, VCE=20V	<60	<60	ohms
Noise Figure	NF	f=300MHz			
		IC=100uA, VCE=10V Rs=1kohms, f=1kHz	-	<4.0	dB
<b><u>DYNAMIC CHARACTERISTICS</u></b>					
Transistors Frequency	ft	IC=20mA, VCE=20V	>250	>300	MHz
Out-Put Capacitance	Cob	VCB=10V, IE=0	<8.0	<8.0	pF
		f=100kHz			
Input Capacitance	Cib	VEB=0.5V, IC=0	<25	<25	pF
		f=100kHz			
<b><u>SWITCHING Time</u></b>					
Delay time	td	IC=150mA, IB1=15mA		<10	ns
Rise time	tr	VCC=30V, VBE=0.5V	-	<25	ns
Storage time	ts	IC=150mA, IB1=		<225	ns
Fall time	tf	IB2=15mA, VCC=30V	-	<60	ns

---

\*Pulse Condition: Pulse Width=300us, Duty Cycle=2%

---

## TO-18 Metal Can Package

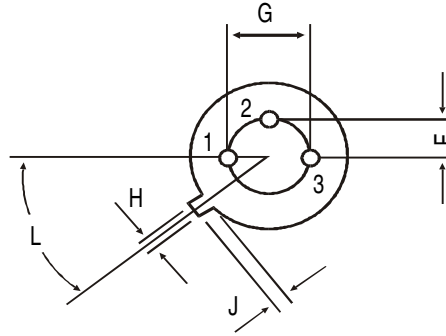
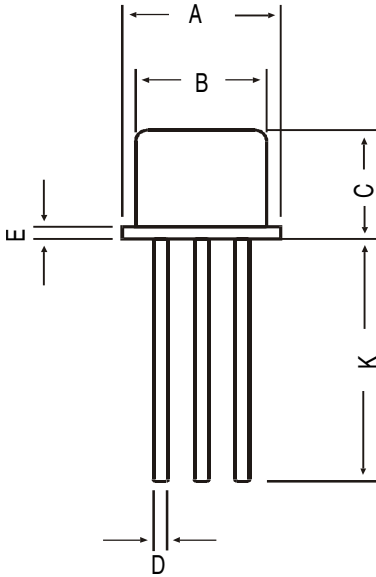

All dimensions in mm.

DIM	MIN	MAX
A	5.24	5.84
B	4.52	4.97
C	4.31	5.33
D	0.40	0.53
E	—	0.76
F	—	1.27
G	—	2.97
H	0.91	1.17
J	0.71	1.21
K	12.70	—
L	45 DEG	

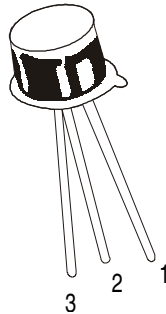

### PIN CONFIGURATION

1. EMITTER
2. BASE
3. COLLECTOR

### Packing Detail

PACKAGE	STANDARD PACK		INNER CARTON BOX		OUTER CARTON BOX		
	Details	Net Weight/Qty	Size	Qty	Size	Qty	Gr Wt
TO-18	1K/polybag	350 gm/1K pcs	3" x 7.5" x 7.5"	5.0K	17" x 15" x 13.5"	80.0K	34 kgs

This datasheet has been download from:

[www.datasheetcatalog.com](http://www.datasheetcatalog.com)

Datasheets for electronics components.