

Description

- General purpose amplifier
- High voltage application

Features

- High collector breakdown voltage : $V_{CBO} = -160V$, $V_{CEO} = -150V$
- Low collector saturation voltage : $V_{CE(sat)} = -0.5V(MAX.)$
- Complementary pair with 2N5551

Ordering Information

Type NO.	Marking	Package Code
2N5401	2N5401	TO-92

Outline Dimensions

unit : mm

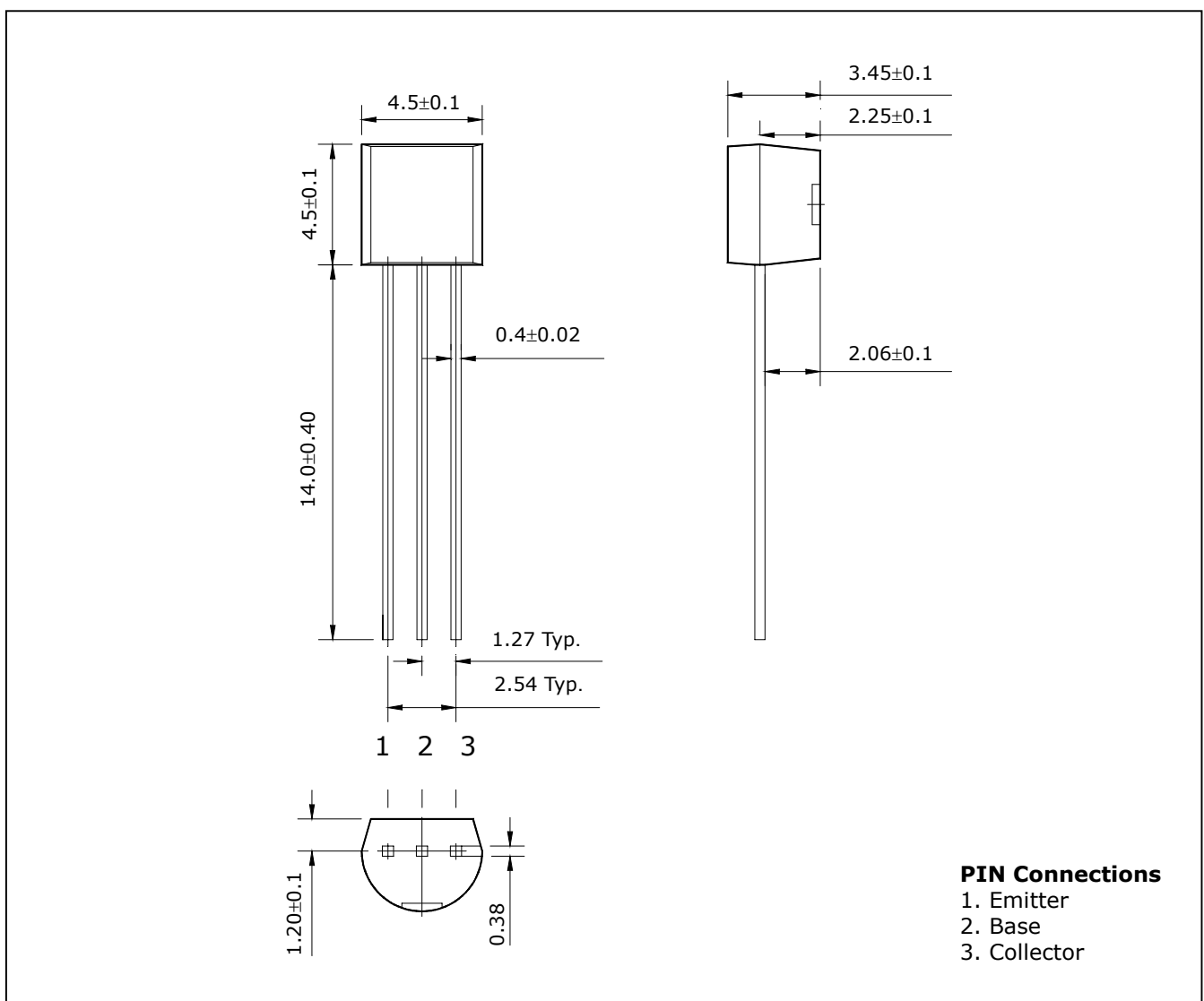

Absolute maximum ratings

(Ta=25°C)

Characteristic	Symbol	Ratings	Unit
Collector-Base voltage	V_{CBO}	-160	V
Collector-Emitter voltage	V_{CEO}	-150	V
Emitter-Base voltage	V_{EBO}	-5	V
Collector current	I_C	-600	mA
Collector dissipation	P_C	625	mW
Junction temperature	T_j	150	°C
Storage temperature	T_{stg}	-55~150	°C

Electrical Characteristics

(Ta=25°C)

Characteristic	Symbol	Test Condition	Min.	Typ.	Max.	Unit
Collector-Base breakdown voltage	BV_{CBO}	$I_C = -100\mu A, I_E = 0$	-160	-	-	V
Collector-Emitter breakdown voltage	BV_{CEO}	$I_C = -1mA, I_B = 0$	-150	-	-	V
Emitter-Base breakdown voltage	BV_{EBO}	$I_E = -10\mu A, I_C = 0$	-5	-	-	V
Collector cut-off current	I_{CBO}	$V_{CB} = -120V, I_E = 0$	-	-	-100	nA
Emitter cut-off current	I_{EBO}	$V_{EB} = -3V, I_C = 0$	-	-	-100	nA
DC current gain	$h_{FE(1)}$	$V_{CE} = -5V, I_C = -1mA$	50	-	-	-
DC current gain	$h_{FE(2)}$	$V_{CE} = -5V, I_C = -10mA$	60	-	240	-
DC current gain	$h_{FE(3)}$	$V_{CE} = -5V, I_C = -50mA$	50	-	-	-
Collector-Emitter saturation voltage	$V_{CE(sat)(1)}^*$	$I_C = -10mA, I_B = -1mA$	-	-	-0.2	V
Collector-Emitter saturation voltage	$V_{CE(sat)(2)}^*$	$I_C = -50mA, I_B = -5mA$	-	-	-0.5	V
Base-Emitter saturation voltage	$V_{BE(sat)(1)}^*$	$I_C = -10mA, I_B = -1mA$	-	-	-1	V
Base-Emitter saturation voltage	$V_{BE(sat)(2)}^*$	$I_C = -50mA, I_B = -5mA$	-	-	-1	V
Transition frequency	f_T	$V_{CE} = -10V, I_C = -10mA$	100	-	400	MHz
Collector output capacitance	C_{ob}	$V_{CB} = -10V, I_E = 0, f = 1MHz$	-	-	6	pF

* : Pulse Tester : Pulse Width $\leq 300\mu s$, Duty Cycle $\leq 2.0\%$

Electrical Characteristic Curves

Fig. 1 $P_C - T_a$

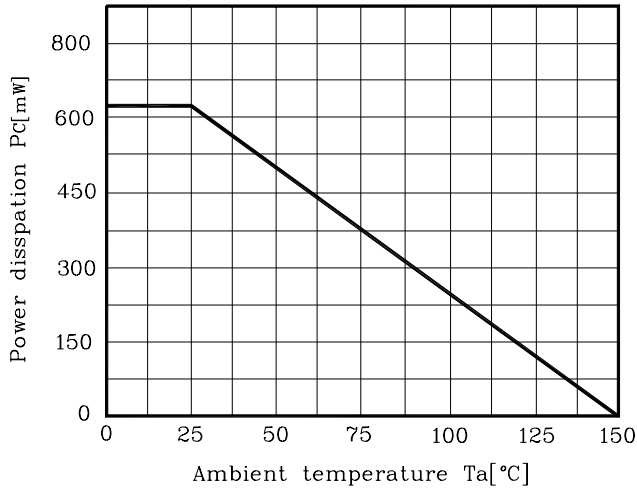

Fig. 2 $I_C - V_{BE}$

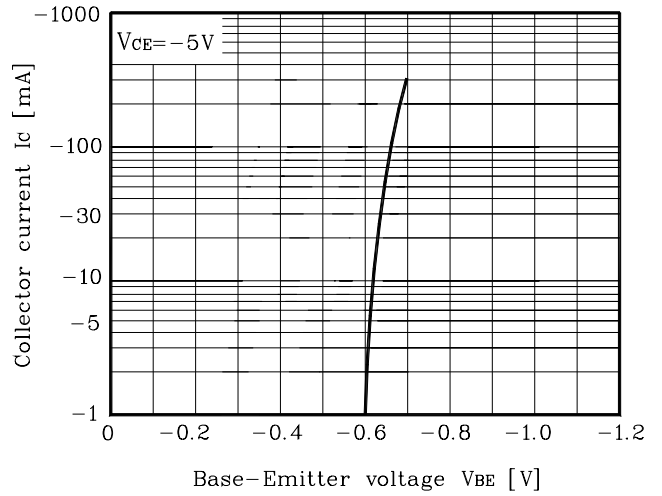

Fig. 3 $f_T - I_C$

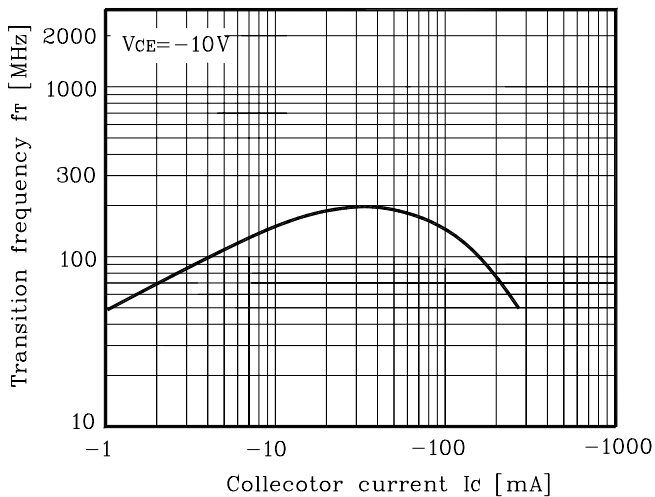

Fig. 4 $V_{CE(sat)}, V_{BE(sat)} - I_C$

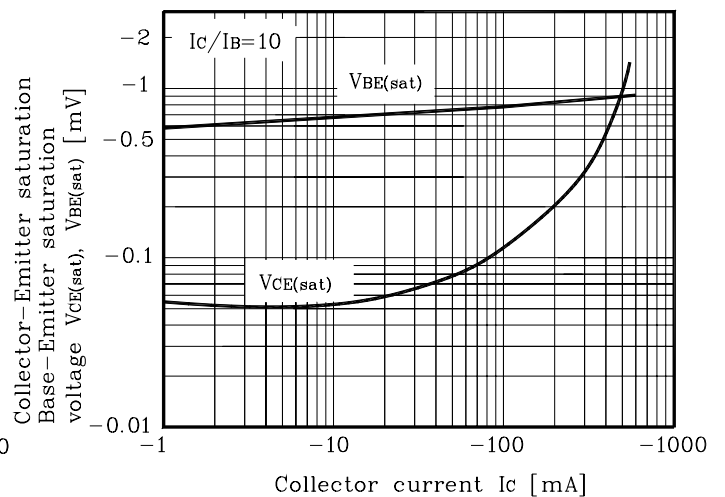
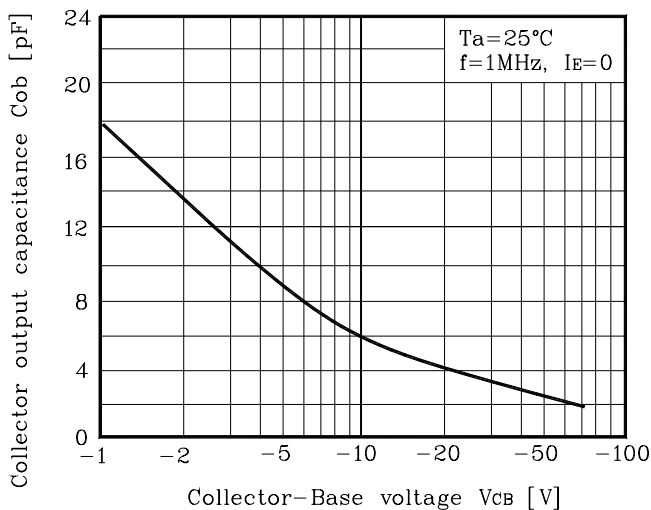

Fig. 5 $C_{ob} - V_{CB}$



This datasheet has been download from:

www.datasheetcatalog.com

Datasheets for electronics components.